

Series KSS

- ✓ DC 3-wire
- ✓ LED display
- ✓ IP67
- ✓ Plastic housing
- ✓ Easy handling
- ✓ Potentiometer adjustable
- ✓ Repeatability <0,2 mm



Compatible to multiple tube diameters
Regardless of the liquid color

Technical data

Type	Tube wall thickness	Tube diameter	Output	Type Output	Voltage range	Output current	Ambient temperature	Connection	Technical drawing
KSS 11 PSLK	≤ 1 mm	∅ 8...11 mm	NO	PNP	10...30 VDC	≤ 200 mA	-25...70 °C	2 m Kabel	Drawing 1
KSS 26 PSLK	≤ 1.5 mm	∅ 12...26 mm	NO	PNP	10...30 VDC	≤ 200 mA	-25...70 °C	2 m Kabel	Drawing 2
KSS 11 POLK	≤ 1 mm	∅ 8...11 mm	NC	PNP	10...30 VDC	≤ 200 mA	-25...70 °C	2 m Kabel	Drawing 1
KSS 26 POLK	≤ 1.5 mm	∅ 12...26 mm	NC	PNP	10...30 VDC	≤ 200 mA	-25...70 °C	2 m Kabel	Drawing 2

Connection diagram

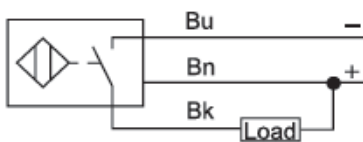

NPN NO

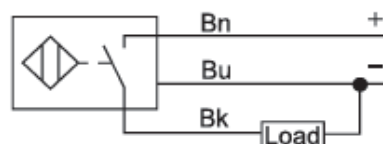

PNP NO

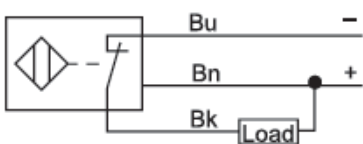

NPN NC

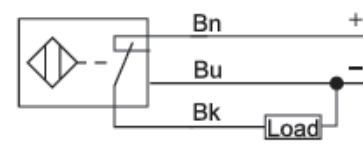

PNP NC

Series KSS

Technical Drawing

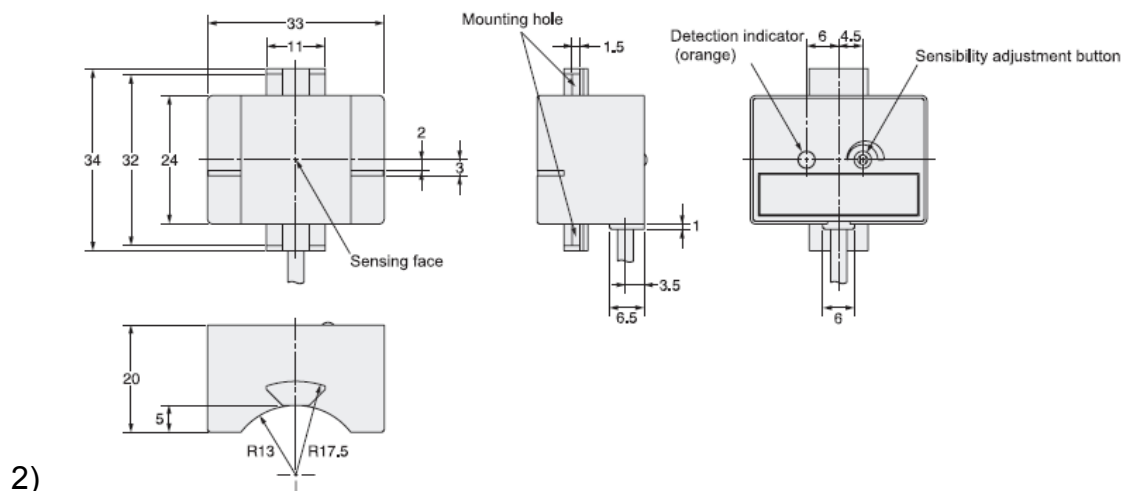
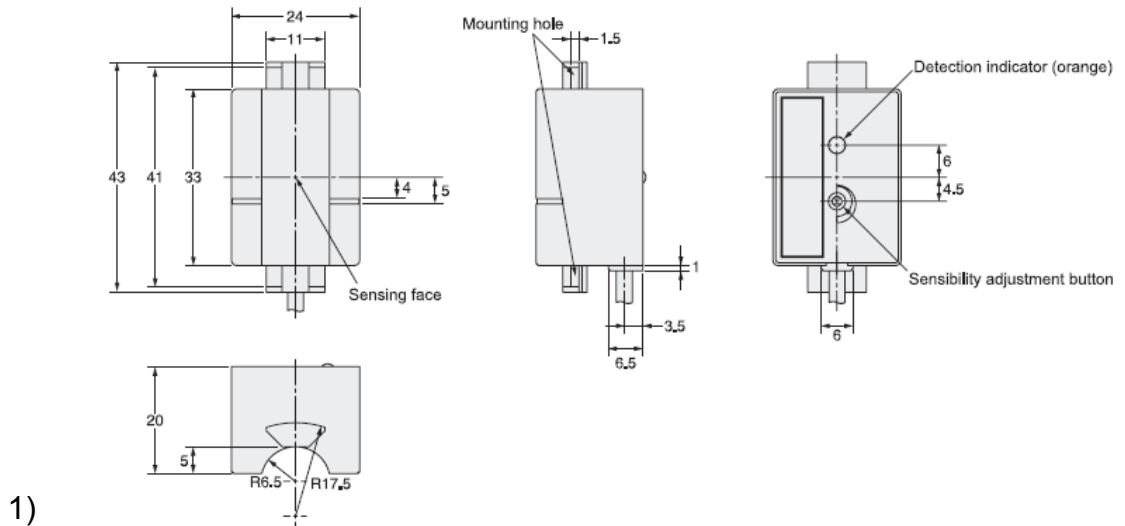

Installation

